



-Innovative Products and Engineering-

Standard Passive Orbital Thermal-control Structures



When thousands of hours go into a mission design, give your satellite the structural and thermal support it deserves.

Standardized structures

Small spacecraft are more valuable and more capable as government and commercial missions push high-tech missions with smaller budgets and shorter schedules. Engineers are tasked with making systems work while often developing mission specific technology. Engineers at TMT asked, "what can we do to simplify the engineering process while enabling high-tech missions?"

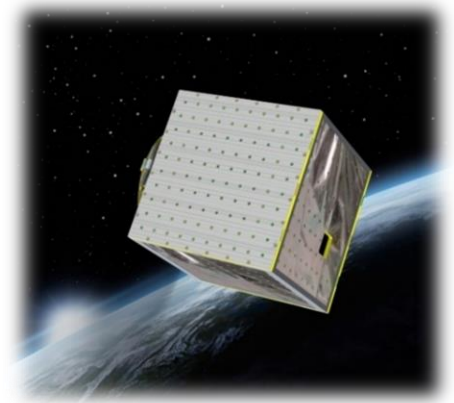

Objective: Simplify design process for satellite engineers and provide increased thermal subsystem capability

The result - Standard, passive, orbital thermal control structures (SPOT)

TMT adapted its multifunctional, heat spreading structure technology and scaled it to smaller satellite configurations. Imagine having a structure that supports your equipment during the rigors of launch and smooths out the temperature extremes in the environment of space. SPOT facilitates use of available satellite area and thermal capacitance.

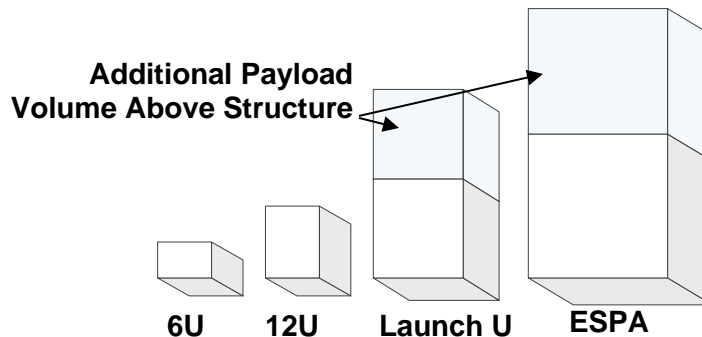

Standard Structure Design:

Standard designs provide ease of component layout. You focus on your exciting new hardware, TMT has taken the worry out of launch vehicle/ dispenser interface. Contact TMT to discuss where holes and penetrations are required for your application.

Contact TMT to discuss your application

Thermal Management Technologies
2465 North 500 West
North Logan, UT 84341
Phone: 435-755-6400
Email: information@tmt-ipe.com
Web: www.tmt-ipe.com

• *Simplified design*

• *Reduced risk*

• *Improved performance*

- Features-

• *Standard spacecraft-dispenser or separation system interface*

- *Custom always available*

• *Integrated heat spreading*

- *3 to 6 times more mass efficient than aluminum*

• *Standard hole pattern*

Small Satellite Structures

12U – PSC Configuration

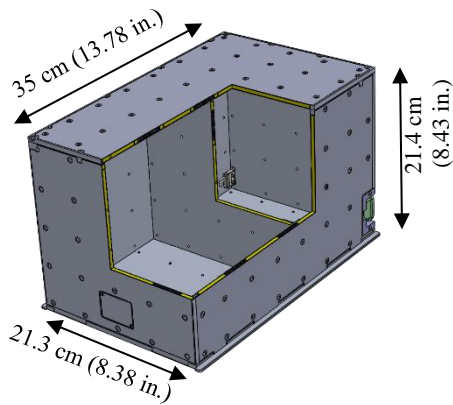

- Deployer Interface – PSC 12U Tab
- Mount for PSC Electrical Connector and 3 Microswitches
- Removable cover for access
- Hardware Interface: 5 cm x 5 cm grid; #4-40 fasteners
- Shelf: Horizontal, Vertical, or None
- Mass: Structure 3.2 kg; Max. 12U total 24 kg

6U – PSC Configuration

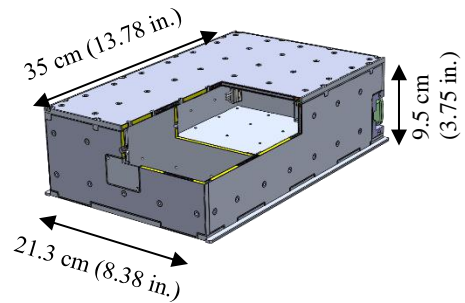

- Deployer Interface - PSC 6U Tab
- Mount for PSC Electrical Connector and 3 Microswitches
- Removable cover for access
- Hardware Interface: 5 cm x 5 cm grid; #4-40 fasteners
- Shelf: Horizontal, Vertical, or None
- Mass: Structure 1.9 kg; Max. 6U total 12 kg

Launch U Configuration

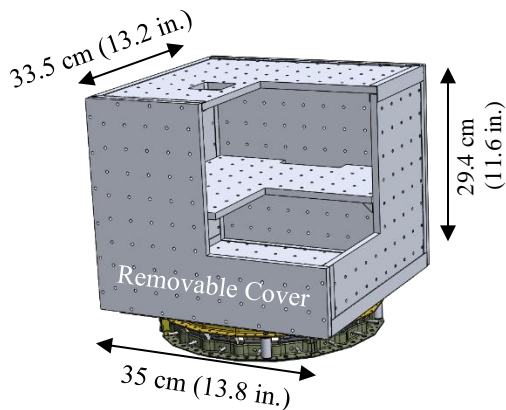

- Deployer Interface – 11.7 in MLB (PSC) (or other)
 - Launch U specifications (Aerospace Corp.)
- 2-Removable covers for access
- Hardware Interface: 5 cm x 5 cm grid; #4-40 fasteners
- Shelf: Horizontal, Vertical, or None
- Mass: Structure 9.8 kg; Max. LU total 80 kg

HALF ESPA – LB Configuration

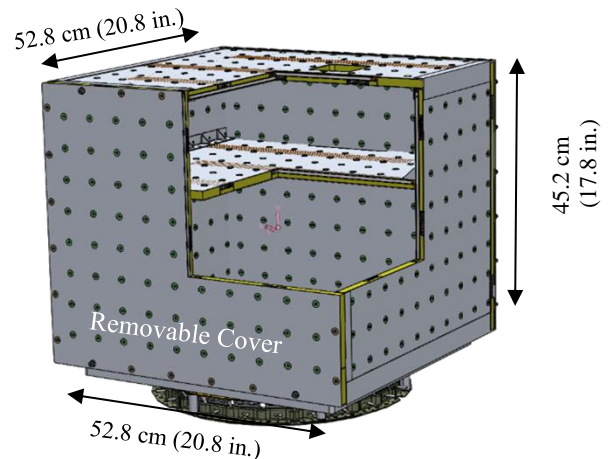

- Deployer Interface – 15. in. MLB (PSC) (or other)
 - ESPA specifications
- 2-Removable covers for access
- Hardware Interface: 5 cm x 5 cm grid; #8-32 fasteners
- Shelf: Horizontal, Vertical, or None
- Mass: Structure 19.8 kg; Max. ESPA total 180 kg

Testing TMT can perform a wide variety of analysis and testing on thermal systems as an added service

Thermal Management Technologies

2465 North 500 West

North Logan, UT 84341

Phone: 435-755-6400

Email: information@tmt-ipe.com

Web: www.tmt-ipe.com

This technology was principally developed under SBIR funding managed by the Air Force Research Laboratory, Space Vehicles Directorate under FA9453-10-C-0053 and FA9453-12-C-0070